

Contents

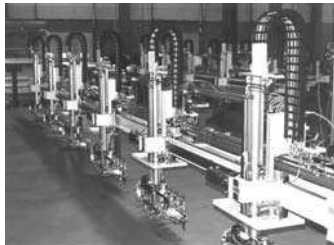

History	p. 18
Fundamentals of Pneumatics	p. 18
Creating Movement with Air	p. 18
Air Can be Pressed Together	p. 19
Creating and Storing Compressed Air – The Compressor	p. 19
Switching Compressed Air – The Electromagnetic Valve	p. 20
Operating a Pneumatic Cylinder	p. 20
Interplay of Electrical and Pneumatic Switching	p. 21
Control Logic with Software ROBO-Pro and fischertechnik Interface	p. 21
The Control Unit	p. 22
Conveyor Belt with Stacking Magazine	p. 23
Machining Station with Defective Part Ejection	p. 25
Sorting System	p. 27
Machining Station with Vacuum Pickup	p. 29
Card Dealer and Card Sorter	p. 31
Trouble Shooting	p. 32

History



Assembly Line

■ Our ancestors used air as a technical aid many millenniums ago. Even today, you certainly still know the bellows, which are used for starting a fire.

Ktesibios from Alexandria in Egypt (born in 296 BC in Alexandria, died in 228 BC) was a Greek technician, inventor and mathematician, who lived in the first half of the third century Before Christ (BC).

One of his most important inventions was a spring catapult (compressed air tension jack): Air was compressed in two bronze cylinders and with this bronze leaf springs were pretensioned. When the valves were opened, objects such as rocks were catapulted through the air due to the releasing of the tension on the leaf springs.

So it is no wonder that the technology of „**pneumatics**“ took its name from the Greek word „**pneuma**“, which translates to „**air**.“

Today's modern industry could not do without pneumatics. You can find pneumatically driven machines and automation systems, which are pneumatically driven, everywhere. In this way, for example, various individual parts are assembled on production lines to form an entire part and checked for proper functioning and goods are also sorted and packaged.

Fundamentals of Pneumatics



Windpower Station

■ Air can be used for various purposes in technology. For example, wind drives giant wind turbine propellers to generate energy. Pneumatics uses air to generate movements and to transfer forces.

You are certainly familiar with a pneumatically operated tool known as an air pump. It has the physical and technical characteristics of the cylinders, which are presented in this construction set, for example, for creating compressed air with a compressor.

Creating Movements with Air

The construction set, ROBO PneuVac, contains two different pneumatic cylinders. For the first experiment, you need the bigger one with the red piston rod and built-in spring.



Air Pump

Pneumatic Cylinders from fischertechnik

The piston rod with the piston is movable and sealed to the cylinder wall with seals.

If you blow air into the cylinder through the connection A, then the piston moves.

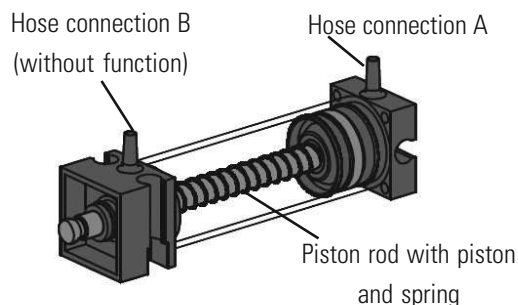

Industrial Version

This cylinder can only be moved pneumatically in one direction. The return to the starting position is done with the aid of a spring. Such cylinders are called „single-acting cylinders.“

Note!

The connection, through which you extend the piston, has the marking „A“ and the piston is retracted by means of a spring.

Air Can be Pressed Together

If you are working with pneumatic systems today, you should know something about the physical characteristics of air. Test this with a small experiment:

Pull the red piston rod of the cylinder completely out. Then close connection A with your finger. Now let go of the piston rod. What do you observe?

The piston rod is just pushed inwards a little by the spring.

Result

The air in the cylinder is pressed together and prevents the piston rod from being moved. The more that the air is pressed together, the greater the air pressure in the cylinder. You can measure the pressure with a pressure gauge or you can also calculate this. The unit for pressure is the „bar“ or „Pascal.“

For this, note the following equation:

$$\text{Pressure} = \text{Force/Area} \text{ or } p = F/A$$

This equation shows that the pressure is dependent on the amount of force exerted on a round area in the cylinder.

Creating Compressed Air and Storing Compressed Air – The Compressor

The compressor, which is contained in the construction set, is built from fischertechnik components. It supplies you with the necessary compressed air, with which you can control the individual models. In industry, this is called the compressed air source.

The Way It Functions

The compressor (1) (cylinder with the black piston rod) is driven by a motor (2). When the piston is lifted, then air is sucked in from outside through the check valve (3). When the piston is lowered, the air is compressed and pressed into the air cell (4). The check value (3) now insures that the air cannot flow back. The air cell insures that you always have enough air to control your models.

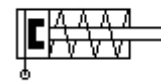

Control diagram single-acting cylinder



Pressure gauge for measuring the air pressure

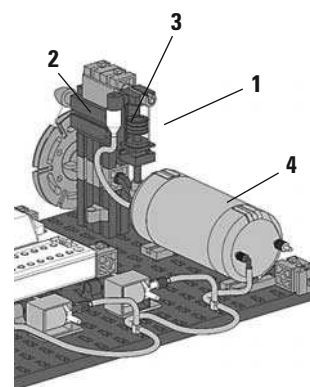

Compressor



Circuit diagram for compressed air source

Note!

The overpressure produced by the compressor is about 0.5 bars. The piston in the compressor must be able to be easily moved. It can be that you must, if necessary, lubricate it with a small drop of acid free oil such as silicone oil.

If you aren't going to use the compressor for some time, it is recommended that you remove the drive belt because this loses its tension with time and then it can slide or break.

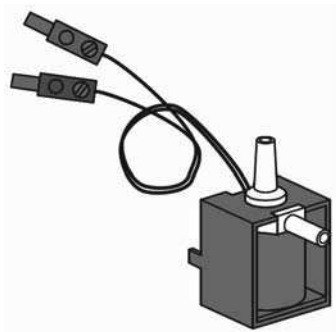

Switching Compressed Air – The Electromagnetic Valve

In pneumatics, the purpose of the valve is to control the flow of air to the pneumatic cylinder so that the cylinder is extended or retracted. The valve can be operated by hand, pneumatically or as is the case for your technical models electromagnetically.

Technical data for the valve: 3/2 way valve 9V, DC, 130 mA

A 3/2 way valve means that it has three connections and two switching conditions.

Note!

When connecting the valve to the power source or to the interface, you don't have to pay attention to insure you have the right polarity.

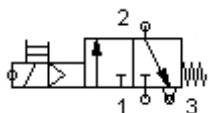

Circuit diagram for a 3/2 way valve

A Short Technical Explanation

When you place voltage on the coil (1) then a magnetic field is formed and pulls the core (2) downwards. The valve opens and the air flows from connection „P“ through connection „A“ to the cylinder. If no voltage is applied, then the core is pushed upwards by a spring (3) and the valve is closed..

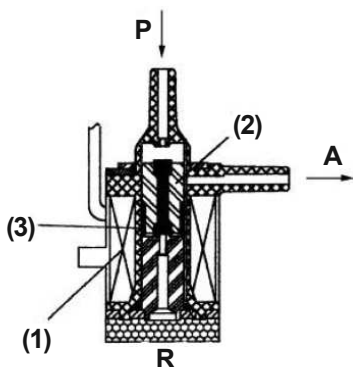

When the valve is closed, then connection „A“ is connected with the air vent „R.“ This is important so that the air can escape from the cylinder.

The connections in the pneumatics are always named as follows:

- P = Compressed air connection**
- A = Connection to the cylinder**
- R = Air vent**

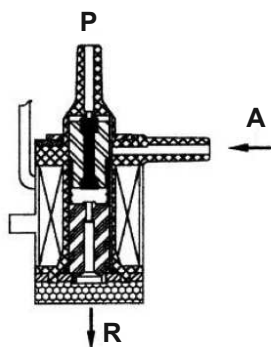

Interplay of Electrical and Pneumatic Switching

Your Task

A single-acting cylinder is to be extended by means of an electromagnetically controlled valve. This is to take place when the user closes a switch. As long as it is closed, the cylinder is to remain extended. When the switch is reset, then the cylinder is to be retracted by the spring pressure.

This task is represented in the technology with symbols. Thus, there is one circuit diagram for the electrical part and one for the pneumatic part.

In the figures presented, the electrical part is on the left and the pneumatic part is on the right. The electrical part consist of a voltage source with a +9 V, the push button and the electromagnetic coil for the valve. The pneumatic part consists of a compressed air source, the valve and the cylinder.

Note!

Since the magnet coil and valve are one unit, these are shown with the same identification. In this way, the coil is clearly assigned to the valve.

The two diagrams on the left, show you the system in the starting position and on the right when the button is pressed. The diagram on the right clearly shows the flow of electricity and air.

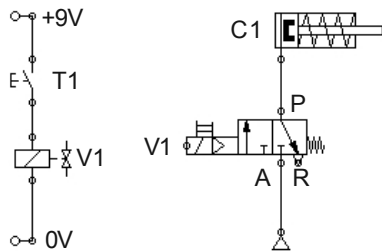

Circuit diagram, electrical, pneumatic part

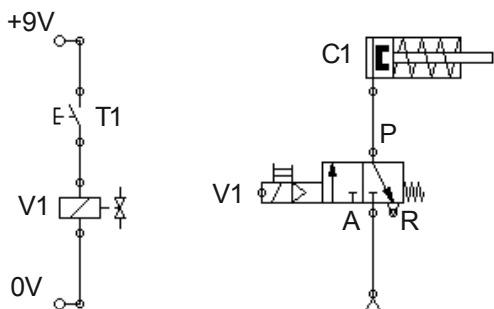

Circuit diagram, starting position

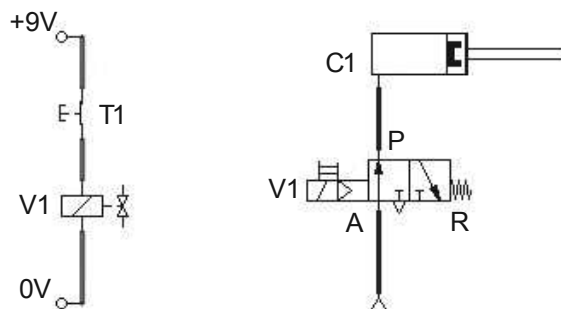

Circuit diagram, button depressed

Control Logic with Software ROBO-Pro and fischertechnik Interface

In addition to your mechanical structure, a system needs control logic, which is software for your PC, and a transmission part, which is the interface that convertst the software commands into executable signals for the machine.

The control software, ROBO-Pro, has a simple graphic programming interface, with which you can make programmms without having to learn a programming language.

You need the ROBO-Pro Version 1.2.1.32 for the construction set, PneuVac. If you have an older version of the software, you can update this at no charge. Download this with the help menu in ROBO-Pro,Download New Version, or at:

„www.fischertechnik.de/robopro/update.html“

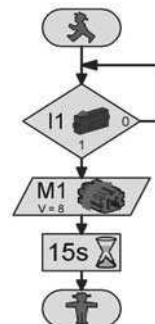
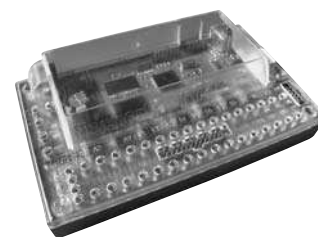

The Control Unit

■ As you learned on the previous pages, you need the compressor as a source of compressed air for the operation of pneumatic models as well as valves and the ROBO Interface (not included in the construction set) for the technical program implementation.

This unit is set up on its own assembly board and can be used for all models so that you don't have to set this up every time.

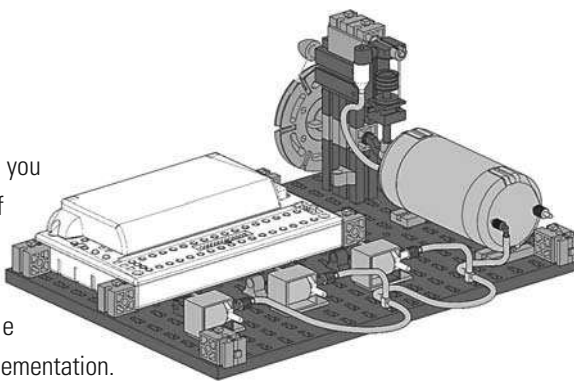

Task 1 Control Unit

Using the construction instructions, assemble the control unit and wire it according to the instructions. Connect the USB cable, which is included, to the interface and to the computer and the power supply (power supply unit).



Actuators

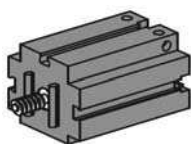

Electric Motor

To drive the compressor, you need an electric motor. This is connected to the interface to output M1. The piston is moved by a flywheel and air is pumped through the check valve into the air cell.

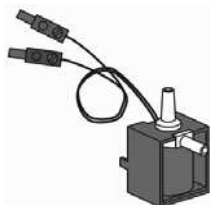

3/2 Way Magnetic Valve

The 3/2 way magnetic valve serves to control the air flow from the compressor to the cylinder. When the valve is open, the compressed air flows to the cylinder and extends or retracts the piston in the cylinder. The red plugs for the magnetic valves are connected to the interface outputs 05, 06 and 07. The cables with the green plugs are connected with the common terminal.

ROBO Interface

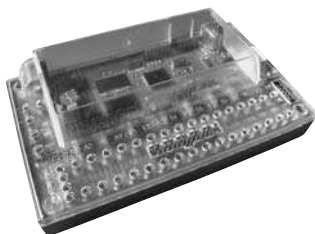

■ The most important component, which is needed to control the valves and the electrical components of the models, is the ROBO interface, which is installed in the control unit. You can connect additional sensors and actuators to this as needed. You can find the instructions for wiring the models in the construction instructions.

Task 2 Testing the Control Unit

Start the ROBO-Pro software. Activate the button  Test. The working screen appears for the testing of the interface and the connected sensors and actuators.



First, turn on the compressor motor and leave it on for about 15 seconds in order to build up pressure in the air cell. To do this, switch the motor to counterclockwise rotation or clockwise rotation with the mouse.



Now, you can test the individual valves. To do this, switch the connections 05 and 06 on and off. You will notice that when the valve is switched air flows out of the connecting piece. Following this, switch all actuators to stop and end the test.



Conveyor belts are the links for industrial plants. So there are assembly lines, filling systems and sorting systems. The conveyor belts here transport components to various working processes.

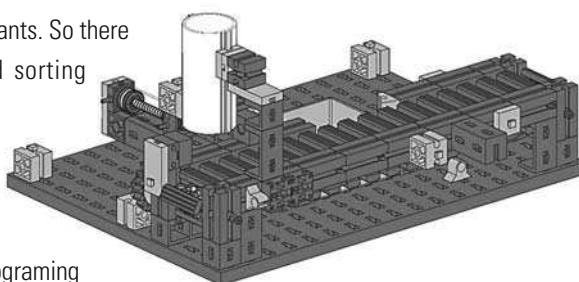

Now you can get started. Now that you have found out how the interface and the programming work, you can solve the first task. First, the conveyor belt with the stacking magazine is to be built using the construction instructions.

Conveyor Belt with Stacking Magazine

Task 1 ROBO-Pro Level 2

If a workpiece is in the stacking box, then this is to be identified by the light barrier. After this, the pneumatic cylinder is to shove the workpiece onto the belt. This is started and transports the rock to the end of the belt. Then, the program stops.



A light barrier is used for the first task. This consists of a light sensitive sensor (phototransistor) and a lens tip bulb as a light source.

Lens Tip Bulb

This is an incandescent bulb with a built-in lens, which focuses the light. You need the lens tip bulb to build a light barrier.



Phototransistor

You can also call the phototransistor a „brightness sensor.“ This is a „sensor“ that reacts to brightness. For a light barrier this is the counterpart to the lens tip bulb. When there is a high degree of brightness, that is when the transistor receives light from the lens tip bulb, it conducts electricity. If the ray of light is interrupted, it does not conduct any electricity. Caution: When connecting the phototransistor, you must pay special attention to the right polarity: red = plus



Actuators

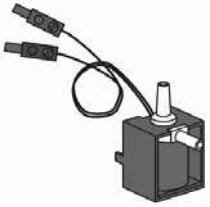

3/2 Way magnetic valve

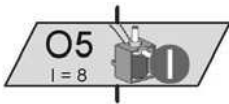

Program depiction
magnetic valve

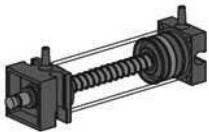

Pneumatic cylinder



Start program in the
online mode.

Note!

The symbol for the bulb output is switched to magnetic valve by right clicking on the symbol in the selection offered there.



In order to have sufficient pressure for the functioning of the cylinder, it is important that you start the buildup of the pressure some time before the machining cycle. Use 15 seconds for this.

Program Test

You can find the finished sample program at:

C:\Programs\Robopro\SamplePrograms\Robo PneuVac\Conveyorbelt_1.rpp

Test the program by starting it in the online mode. You can observe the program sequence precisely on the screen. When the red light figure is reached, the program is finished.

Task 2 ROBO-Pro Level 2

Expand task 1 with the following work step: Every two seconds, a workpiece is to be shoved from the stacking magazine onto the conveyor belt. All workpieces run to the end of the belt. When the last workpiece is shoved onto the belt, it is to stop after 10 seconds.



Note!

If you are working with an endless loop, then the „red light figure“ is not used. You can find additional information on this in the ROBO-Pro Handbook.

After the programing, test the program in the online mode.

Sample program: **Conveyorbelt_2.rpp**

■ In particular in the mechanical production of workpieces, it may be required that defective parts are identified and sorted out before further processing is conducted. Special detection systems examine the components and mark those, which are not usable, and sort them out.

Special sensors record the defective parts and allow them to be sorted out directly on the conveyor belt. It is only the perfect workpiece that is allowed to go to the succeeding machining systems.

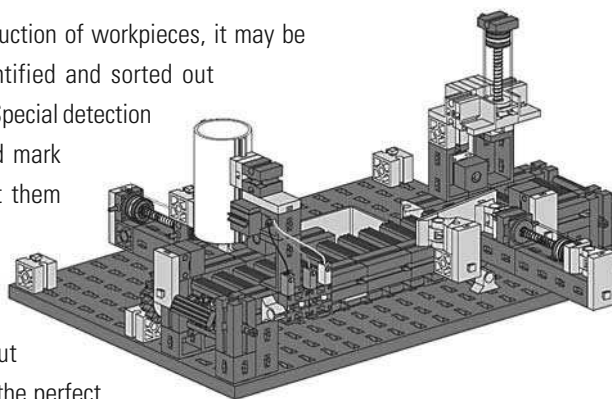

Machining station with defective part ejection

Build the model machining station with defective part ejection using the construction instructions. Wire and connect the electrical and the pneumatic elements.

Task 1 ROBO-Pro Level 2

If a workpiece is in the stacking magazine, it is to be shoved onto the conveyor belt. Then the conveyor belt starts. A second light barrier on the machining station identifies the workpiece and stops the belt and starts the machining. The stamp is extended pneumatically, remains one second and then returns to the home position. Then the belt starts again and transports the workpiece to the end of the belt and stops. Following this, the process is repeated again.



■ In addition to the main program, you can make subprograms. These are used so that the program structure remains clear and subprograms, which have been prepared, can also be copied to other applications. You can find additional information on this in the ROBO-Pro Handbook.

Sample Program: **Machiningstation_1.rpp**

Subprogram



Subprogram

Actuator

Optical Color Sensor

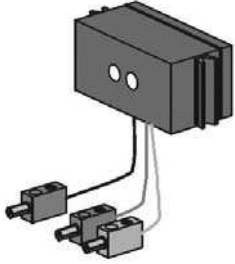

Note! The distance between the sensor and the workpiece should be about 15 mm.

Color	Value
White	
Red	
Blue	

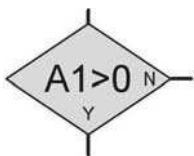

Inquiry symbol for interface connection A1

■ Color sensors are mostly used in automation technology. When this is done, for example, the color or the color imprint is to be examined to insure that the correct components are installed. The fischertechnik color sensor transmits red light, which is reflected with a different intensity from different colored surfaces. The quantity of the reflected light is measured by the phototransistor and outputted as an analog value in ROBO-Pro.

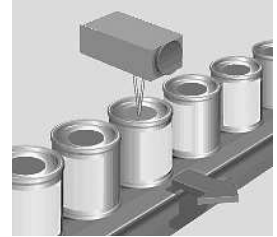

Sorting of incorrect cans

The measured value is dependent on the ambient brightness and the distance of the sensor from the colored surface. You can read in this value through the analog inputs A1 and A2 and process the numerical value from 0 to 1023 in your program.

The color sensor is installed in your model. It is connected with the black and the green cable to A1 and with the red cable to + (see circuit diagram in the construction instructions).

Task 2 ROBO-Pro Level 2

First check the values that the interface puts out for the colored workpieces in the interface test (white, red, blue).

Make a small table and enter the values, which you have measured. Also observe the changes when the distance to the colored surface or the ambient light changes.



Task 3 ROBO-Pro Level 3

The color sensor is used to sort the workpieces based on their color. Only white workpieces, which are without defects, are to reach the machining station. Blue and red workpieces are to be sorted out using a „sorter.“



Tip

For the programming, think about how the sequence of the sorting runs. Here is a little help:

- Switch on the compressor
- Start the system after the pressure is built up.
- Eject the individual workpieces with cylinder 1
- Check the colors with the color sensor
- Start the conveyor belt
- Possibly use the sorter with cylinder 2
- Machining of the „good“ workpieces
- Transport to the end of the conveyor belt.

Sample Program: **Machiningstation_2.rpp**

Sorting system

■ In particular in industrial plants, materials or objects must be sorted out or distributed. One example of this is the sorting system for luggage at airports or the sorting of packages and packets.

Using the construction instructions, build the model. Use the different colored workpieces, which are in the construction set, for this model as well.

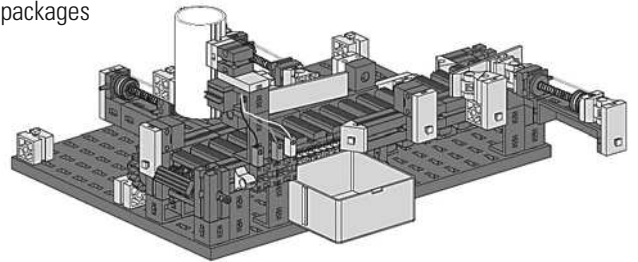

Task 1 ROBO-Pro Level 2

Check the values that the interface puts out for the three colors in the interface test here as well (white, red, blue).

Again, make a small table and enter the values, which you have determined. Also observe the changes in the values shown, when the distance to the colored surface or the ambient light changes.



Note!

The distance between the sensor and the workpiece should be about 15 mm.

Task 2 ROBO-Pro Level 3

As you have already seen in the construction instructions, two sorters are installed in the model. This means that the program can sort three different colors.

Make a program, which first sorts out white workpieces, then red and finally blue. If no more workpieces are in the stacking magazine, then the belt stops and the system waits for workpieces to be inserted into the stacking magazine.



Color	Value
White	
Red	
Blue	

Sample Program: **Sorter.rpp**

Machining station with vacuum pickup



Circuit diagram suction cup

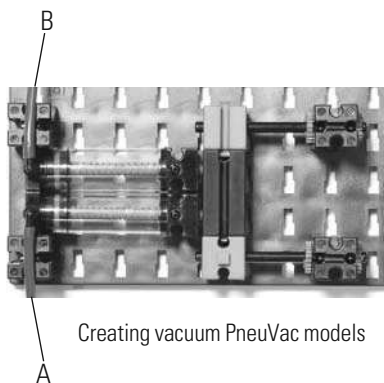

Creating vacuum PneuVac models

■ Machining stations with vacuum pickups are found in many industrial plants and manufacturing plants today. For example, wooden boards are transported to CNC machines and individual parts are placed in position for assembly.

The heart of such a machining station is a vacuum pump.

This generates a vacuum in the suction cup. With this vacuum, a workpiece can be sucked in with the suction cup and then lifted.

The bellows suction cup has a lifting function and can be used on flat as well as on slightly curved surfaces.

Vacuum Pump

Of course, you need a vacuum pump for your model. Since vacuum pumps, which are used in industry, are very expensive, you will generate the vacuum with a simpler solution. You need two cylinders, which are connected with the piston rods. The connection A is connected with the electromagnetically controlled valve and the air source and the connection B is connected with the suction cup. When the valve is activated, both pistons are shoved forward. When the suction cup is sitting on the object to be lifted, the air is sucked out by the second piston and a vacuum is created.



Industrial version „vacuum pump“



Bellows suction cup



Component transport using a vacuum pickup

Task 1 ROBO-Pro Level 2

Using the construction instructions, build the model. Connect the electrical and the pneumatic elements using the circuit diagrams. To test the functioning of the vacuum pump, a workpiece is to be raised with the suction cup and then put back in the same place.



Note!

As was the case for all previous controls, the compressed air supply must be assured. For this, you can of course install the subprogram, „compressor,“ in your program.

Sample Program: **Vacuumpickup_1.rpp**



Compressor

Task 2 ROBO-Pro Level 2

After you have tested the lifting mechanism, your next task is to control the placing of working materials in position. In your case, this is the workpieces, which are contained in the construction set. These are to be stacked in a magazine. Using the installed cylinder, they are to be shoved „individually“ to the pickup position.



From a technical circuit aspect, the task is as follows:

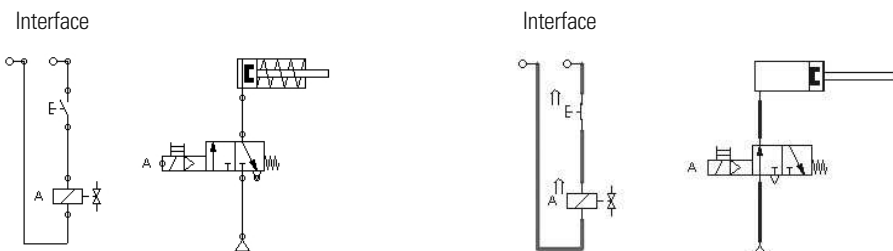

In the interface, using the program sequence diagram voltage is placed (as for a switch) on the valve. In this way, the circuit is closed and the valve releases the air flow for the cylinder. This extends and shoves the component to the pickup position. If the interface interrupts the circuit, the valve closes and due to the effect of the spring in the cylinder, the cylinder moves back to its home position.

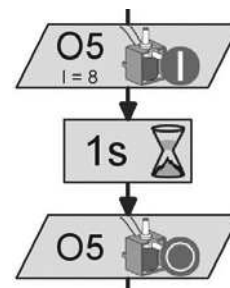

Sample Program: **Vacuumpickup_2.rpp**

Task 3 ROBO-Pro Level 2

Before you program the entire system, you should solve this task. The swivel arm is to rotate to the position „workpiece pickup,“ then to „workpiece machining“ and finally to „workpiece storage.“ The travel to the end position is controlled by a light barrier. You must determine the other positions using a time factor.



Sample Program: **Vacuumpickup_3.rpp**

Task 4 ROBO-Pro Level 2

Rotate the arm to the pickup position. Check to see if a workpiece is in the magazine. If this is the case, then it is to be shoved out of the magazine. The workpiece is picked up with the vacuum lifter and moved to the machining station and there it is set down, machined and then once again lifted by the vacuum lifter, transported to the storage position and then set down.



Sample Program: **Vacuumpickup_4.rpp**

Card dealer

Card sorter

■ Card Dealer

Of course, you don't do this like in the wild west. Today, your model and the corresponding program will help you with dealing the cards. For the programming task, you can cut out the colored cards from the construction instructions or, for example, use rummy cards.

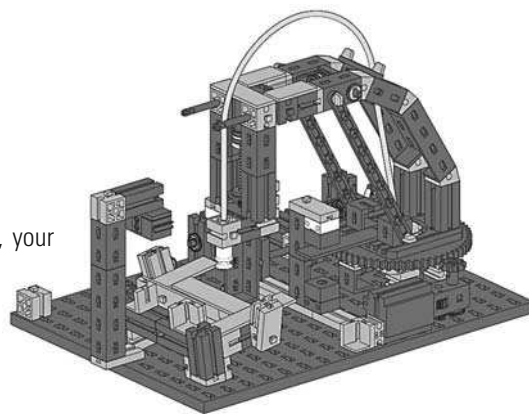

Task 1 ROBO-Pro Level 2

Using the construction instructions, build the model. Connect the electrical and the pneumatic elements using the template. To test the functioning of the vacuum pump, a playing card is to be raised with the suction cup and then put back in the same place.



Sample Program: **Carddealer_1.rpp**

Task 2 ROBO-Pro Level 2

A round of cards consists of three players, who are each to receive three cards from the stack of cards. Make a program, which moves the arm to the pickup position. There, the first card is to be picked up and placed on the storage stack for the first player. Then, the first card for the second and the third player follows. Following this, all players are given the remaining cards.



Sample Program: **Carddealer_2.rpp**

Note!

As for the previous models, make sure that the distance between the sensor and the card surface is about 15 mm.

Programming professionals can try out their skills on the following tasks. Okay, let's get started.

Task 3 ROBO-Pro Level 2

Expand the program so that the program is interrupted if no more cards are available. It is only to continue when you put in more cards.



Sample Program: **Carddealer_3.rpp**

Task 4 ROBO-Pro Level 3

It can happen that a card is not sucked up with the suction cup. Therefore, the program is to check this. One card is to be picked up. The presence of the card is to be checked by the extension of the arm under the color sensor. This is to be done until all players have their cards.



Finished Program: **Carddealer_4.rpp**

■ Sorting Cards

Of course, you will not find this application example anywhere in industry, however, the program can be very helpful because it sorts your cards according to color.

For this purpose, the playing cards are lying with the colored reverse side facing up in the stacking box. The best thing to do is to use a game with two different colors on the back of the cards or use the colored cards in the construction instructions. In this way, the color values for the color identification can be well defined.



Colored back of the playing cards

Task 5 ROBO-Pro Level 3

As in task 3, first it is to be determined if cards are available. If this is the case, the first card is picked up and moved under the color sensor. This determines the color value of the card. Following this, the card is placed on the assigned stacking place. This is followed by additional sorting cycles. If no more cards are available, the program stops.



Sample Program: **Cardsorter.rpp**

If something doesn't work right.

What is worse than a model, which has been put together and connected and then it doesn't work? Therefore, we want to give you a few tips about what the problem could be in the individual case and how you can eliminate the problem.

Problem	Possible Cause	Solution
The compressor runs very slowly. The motor stops as soon as pressure is to be generated.	<p>The power supply for the motor is not sufficient.</p> <p>The compressor cylinder is dry and is hard to move by hand. In this case, the cylinder wall shows clear wear.</p>	<p>Use fischertechnik power unit item No. 37109 or rechargeable battery set item No. 34969. Set the motor speed to the highest level in the program.</p> <p>If the seal in the piston has not been bent, lubricate the cylinder with a small drop of acid free oil. Otherwise replace the worn cylinder.</p>
The compressor motor runs, but the flywheel doesn't move.	The rubber ring is worn out or greasy and slips.	Clean the rubber ring and adapter tip on the motor with some water and soap. Replace rubber ring if worn.
Apparently the compressor is running normally, but the pneumatic cylinder, which is to be activated, moves very slowly or not at all.	<p>Air cell empty</p> <p>Compressor builds up no pressure or too little pressure. Test: Close all openings on the air cell, fill the air cell with compressed air for about 15 seconds. Open a connecting pipe and you should hear a loud hissing sound. If there is no hissing sound or only a weak hissing sound then there is too little pressure.</p> <p>Possible causes of a defective compressor</p> <p>Air cell is leaking. Test: As above, fill with compressed air and place it in water. If bubbles rise then it is leaking.</p> <p>Check valve defective. Test:</p> <p>a) The check valve must be pressure sealed in the blocking direction, which means you should not be able to blow any air into the hose connection or be able to push air in with a cylinder.</p> <p>b) Close the hose connection with a P plug (item No. 31708). Sucking in air when the hose connection is closed should be possible. Blowing out air should not be possible when the hose connection is closed.</p> <p>Compressor cylinder is leaking. Test: Push the piston rod into the cylinder and close connection A with a P plug (item No 31708). Generate a vacuum in the cylinder by pulling the piston rod outwards. If you let go of the piston rod then it must move back to its original position.</p> <p>Pneumatic cylinder is leaking. Test: Pull the piston rod out of the cylinder and when the piston rod is pulled out close connection A with a P plug (item No 31708). When you push the piston rod back into the cylinder you must be able to feel resistance. If you let go of the piston rod then it should move back out on its own.</p>	<p>Close all valves and wait about 15 seconds until the air cell is filled.</p> <p>Check possible causes of a defective compressor.</p> <p>Replace air cell.</p> <p>Replace check valve.</p> <p>Replace compressor cylinder.</p> <p>Replace pneumatic cylinder.</p>
Compressor and all cylinders are okay. In spite of this, one of the cylinders does not extend.	Hose is clogged at one point. Test: Connect each hose individually to the compressor. You can hear and feel if air is passing through the hose.	If necessary, replace clogged hose.

